

# 1550 nm Single-mode SFP Transceiver, 23dB margin

## Small Form Pluggable (SFP), 3.3V

### 1.25 Gbps Gigabit Ethernet



#### Features

- Compliant with IEEE802.3z Gigabit Ethernet Standard
- Compliant with Fiber Channel 100-SM-LC-L standard
- Industry standard small form pluggable (SFP) package
- Duplex LC connector
- Differential PECL inputs and outputs
- Single power supply 3.3V
- TTL signal detect indicator
- Hot Pluggable
- Class 1 laser product complies with EN 60825-1

#### Application

- Distributed multi-processing
- Switch to switch interface
- High speed I/O for file server
- Bus extension application
- Channel extender, data storage

#### Ordering Information

PART NUMBER	INPUT/OUTPUT	SIGNAL DETECT	VOLTAGE	TEMPERATURE
MGBIC-ZX	AC/AC	TTL	3.3V	0°C to 70°C

#### Absolute Maximum Ratings

PARAMETER	SYMBOL	MIN	MAX	UNITS	NOTE
Storage Temperature	$T_S$	-40	85	°C	
Supply Voltage	$V_{CC}$	-0.5	6.0	V	
Input Voltage	$V_{IN}$	-0.5	$V_{CC}$	V	
Output Current	$I_o$	---	50	mA	
Operating Current	$I_{OP}$	---	400	mA	

### Recommended Operating Conditions

PARAMETER	SYMBOL	MIN	MAX	UNITS	NOTE
Ambient Operating Temperature	$T_{AMB}$	0	70	°C	
Supply Voltage	$V_{CC}$	3.1	3.5	V	
Supply Current	$I_{TX} + I_{RX}$	---	300	mA	

### Transmitter Electro-optical Characteristics

$V_{CC} = 3.1 \text{ V to } 3.5 \text{ V}, T_A = 0^\circ \text{C to } 70^\circ \text{C}$

PARAMETER	SYMBOL	MIN	TYP.	MAX	UNITS	NOTE
Output Optical Power 9/125 $\mu\text{m}$ fiber	$P_{out}$	-1	---	+4	dBm	Average
Extinction Ratio	$ER$	7	---	---	dB	
Center Wavelength	$\lambda_C$	1530	1550	1570	nm	
Spectral Width (-20dB)	$\Delta\lambda$	---	---	1	nm	
Side Mode Suppression Ratio	$SNSR$	30	---	---	dB	
Rise/Fall Time, (20–80%)	$T_{r,f}$	---	---	260	ps	
Relative Intensity Noise	$RIN$	---	---	-120	dB/Hz	
Total Jitter	$TJ$	---	---	227	ps	
Output Eye	Compliant with IEEE802.3z					
Max. $P_{out}$ TX-DISABLE Asserted	$P_{OFF}$	---	---	-35	dBm	
Differential Input Voltage	$V_{DIFF}$	0.65	---	2.0	V	
Transmit Fault Output-Low	$TX\_FAULT_L$	0.0	---	0.5	V	
Transmit Fault Output-High	$TX\_FAULT_H$	2.4	---	$V_{CC}$	V	
TX_DISABLE Assert Time	$t_{off}$	---	---	10	$\mu\text{s}$	
TX_DISABLE Negate Time	$t_{on}$	---	---	1	ms	
Time to initialize, include reset of TX_FAULT	$t_{init}$	---	---	300	ms	
TX_FAULT from fault to assertion	$t_{fault}$	---	---	100	$\mu\text{s}$	
TX_DISABLE time to start reset	$t_{reset}$	10	---	---	$\mu\text{s}$	

## Receiver Electro-optical Characteristics

 $V_{CC} = 3.1 \text{ V to } 3.5 \text{ V}, T_A = 0^\circ \text{ C to } 70^\circ \text{ C}$ 

PARAMETER	SYMBOL	MIN	TYP.	MAX	UNITS	NOTE
Optical Input Power-maximum	$P_{IN}$	-3	---	---	dBm	BER < $10^{-12}$
Optical Input Power-minimum (Sensitivity)	$P_{IN}$	---	-26	-24	dBm	BER < $10^{-12}$
Operating Center Wavelength	$\lambda_C$	1100	---	1600	nm	
Optical Return Loss	ORL	12	---	---	dB	
Receiver Electrical 3dB Upper Cutoff Frequency	---	---	---	1500	MHz	
Signal Detect-Asserted	$P_A$	---	---	-23	dBm	
Signal Detect-Deasserted	$P_D$	-31	---	---	dBm	
Differential Output Voltage	$V_{DIFF}$	0.37	---	2.0	V	
Data Output Rise, Fall Time (20–80%)	$T_{r,f}$	---	---	0.35	ns	
Receiver Loss of Signal Output Voltage-Low	$RX\_LOS_L$	0	---	0.5	V	
Receiver Loss of Signal Output Voltage-High	$RX\_LOS_H$	2.4	---	$V_{CC}$	V	
Receiver Loss of Signal Assert Time (off to on)	$t_{A,RX\_LOS}$	---	---	100	$\mu\text{s}$	
Receiver Loss of Signal Assert Time (on to off)	$t_{D,RX\_LOS}$	---	---	100	$\mu\text{s}$	

## Block Diagram of Transceiver

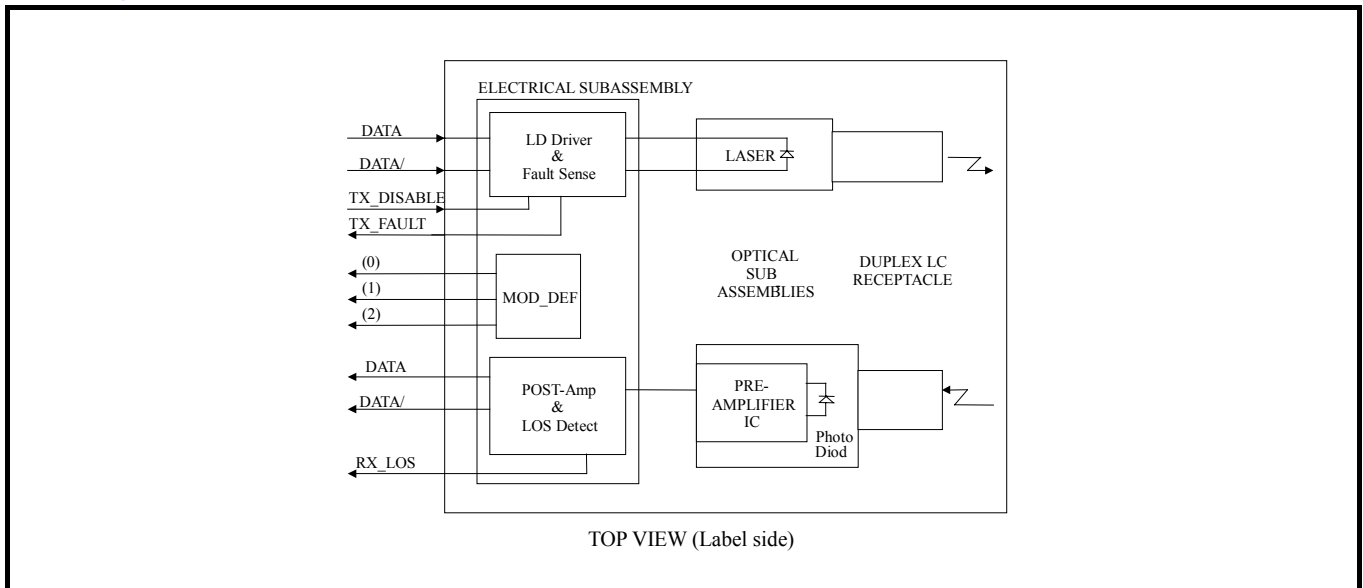

### Transmitter Section

The transmitter section consists of a 1550 nm InGaAsP laser in an eye safe optical subassembly (OSA) which mates to the fiber cable. The laser OSA is driven by a LD driver IC which converts differential input LVPECL logic signals into an analog laser driving current.

### TX\_FAULT

When sensing an improper power level in the laser driver, the SFP set this signal high and turns off the Laser. TX\_FAULT can be reset with the TX\_DISABLE line. The signal is in LVTTTL level.

### TX\_DISABLE

The TX\_DISABLE signal is high (TTL logic "1") to turn off the laser output. The laser will turn on within 1ms when TX\_DISABLE is low (TTL logic "0").

### Receiver Section

The receiver utilizes an InGaAs PIN photodiode mounted together with a trans-impedance preamplifier IC in an OSA. This OSA is connected to a circuit providing post-amplification quantization, and optical signal detection.

### Receive Loss (RX\_LOS)

The RX\_LOS is high (logic "1") when there is no incoming light from the companion transceiver. This signal is normally used by the system for the diagnostic purpose. The signal is operated in LVTTTL level.

**Typical BER Performance of Receiver versus Input Optical Power Level**

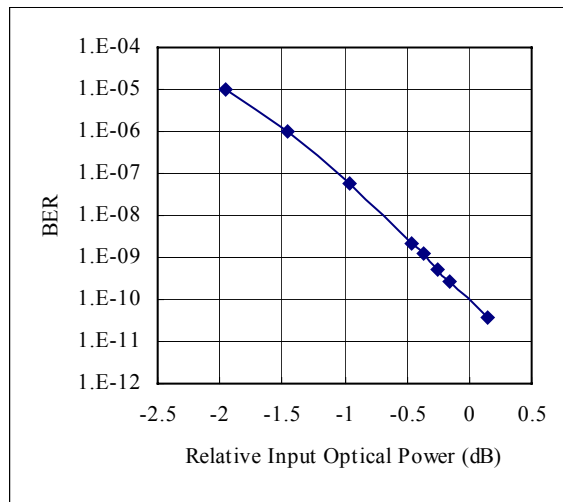

The figure shows the relationship between typical trade-off of BER and Relative Input Optical Power. Besides the required BER =  $1 \times 10^{-12}$  of the Gigabit Ethernet Physical Layer Standard, the transceiver can be operated at other Bit-Error-Rate conditions. The Relative Input Optical Power in dB is referenced to the actual sensitivity of the device. For BER conditions better than  $1 \times 10^{-12}$ , more input signal is needed (+dB).

**Eye Diagram**

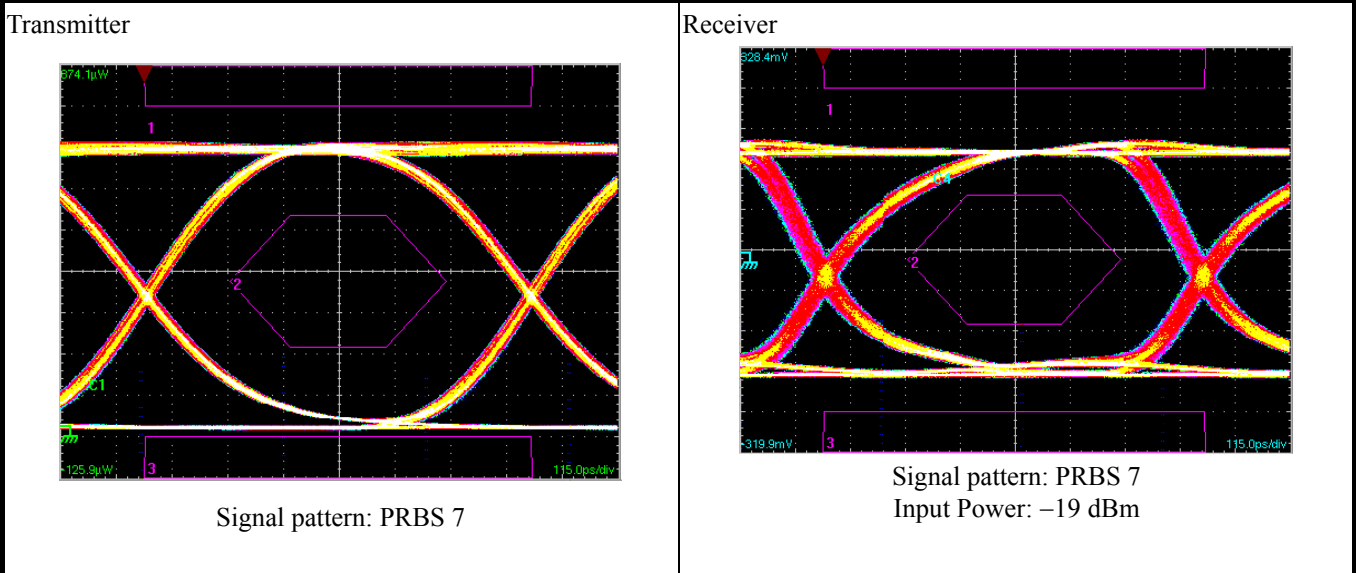

**Dimensions**

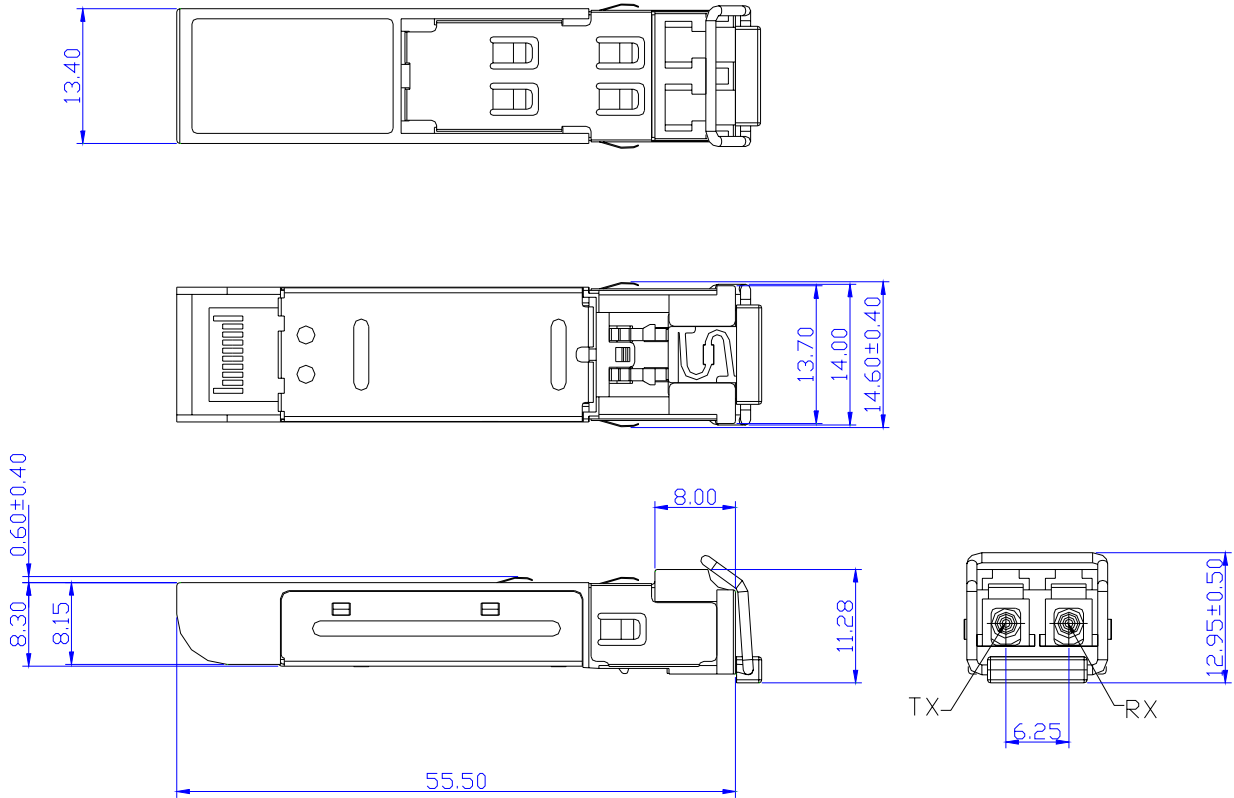

**DIMENSIONS ARE IN MILLIMETERS**

**ALL DIMENSIONS ARE ± 0.2mm UNLESS OTHERWISE SPECIFIED**

Unit: mm



Assembly drawing

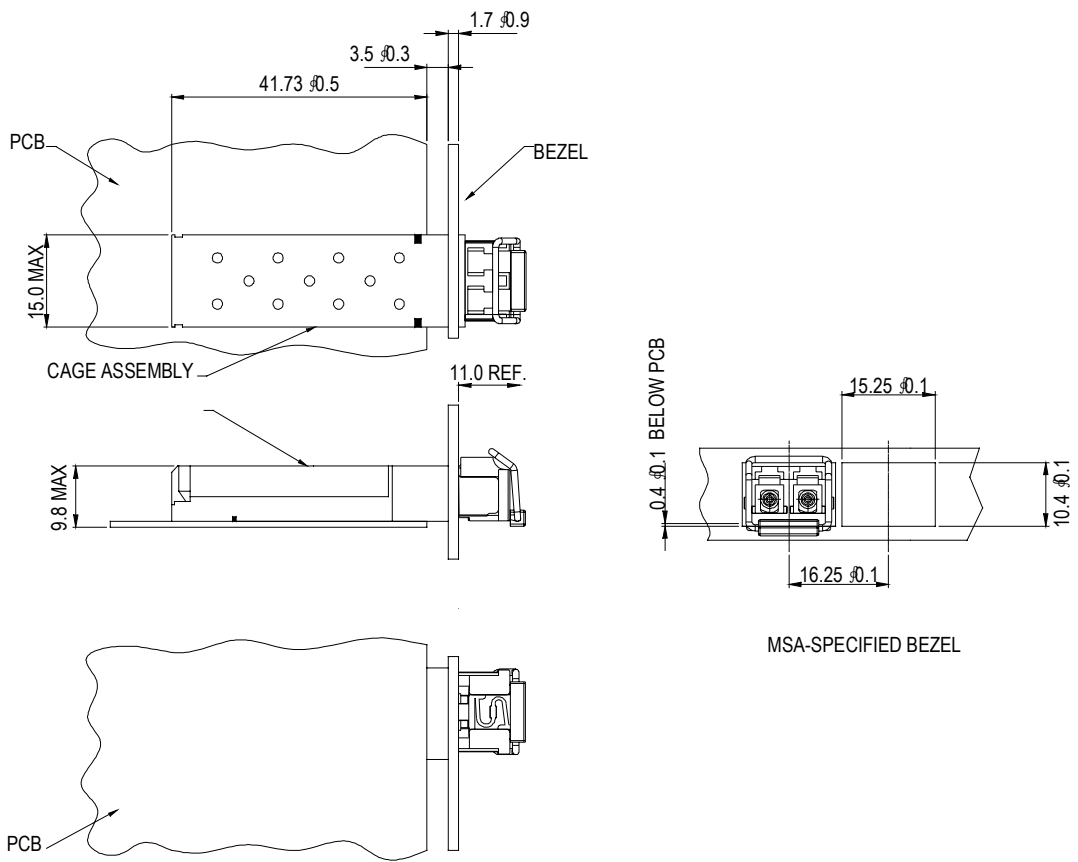

DIMENSIONS ARE IN MILLIMETERS

Unit: mm

## Pin Assignment

Pin-Out

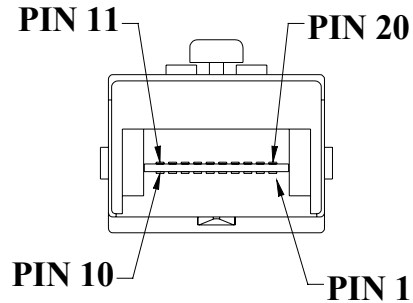

Pin	Signal Name	Description
1	$T_{GND}$	Transmit Ground
2	$TX\_FAULT$	Transmit Fault
3	$TX\_DISABLE$	Transmit Disable
4	$MOD\_DEF (2)$	SDA Serial Data Signal
5	$MOD\_DEF (1)$	SCL Serial Clock Signal
6	$MOD\_DEF (0)$	TTL Low
7	$RATE\_SELECT$	Open Circuit
8	$RX\_LOS$	Receiver Loss of Signal, TTL High, open collector
9	$R_{GND}$	Receiver Ground
10	$R_{GND}$	Receiver Ground
11	$R_{GND}$	Receiver Ground
12	$RX-$	Receive Data Bar, Differential PECL, AC coupled
13	$RX+$	Receive Data, Differential PECL, AC coupled
14	$R_{GND}$	Receiver Ground
15	$V_{CCR}$	Receiver Power Supply
16	$V_{CCT}$	Transmitter Power Supply
17	$T_{GND}$	Transmitter Ground
18	$TX+$	Transmit Data, Differential PCEL, AC coupled
19	$TX-$	Transmit Data Bar, Differential PCEL, AC coupled
20	$T_{GND}$	Transmitter Ground

**Eye Safety Mark**

<p>Singlemode transceiver is a class 1 laser product. It complies with EN 60825-1 and FDA 21 CFR 1040.10 and 1040.11. In order to meet laser safety requirements the transceiver shall be operated within the Absolute Maximum Ratings.</p> <p><b><u>Caution</u></b> All adjustments have been done at the factory before the shipment of the devices. No maintenance and user serviceable part is required. Tampering with and modifying the performance of the device will result in voided product warranty.</p>	<p><b><u>Required Mark</u></b></p> <div data-bbox="810 376 1197 504" style="border: 1px solid black; border-radius: 10px; padding: 5px; text-align: center;"><p><b>Class 1 Laser Product Complies with 21 CFR 1040.10 and 1040.11</b></p></div>
---	---

Note: All information contained in this document is subject to change without notice.