

1550nm Single-mode Transceiver 70km

Gigabit Interface Converters (GBIC), 3.3V/5V

1.25 Gbps Gigabit Ethernet

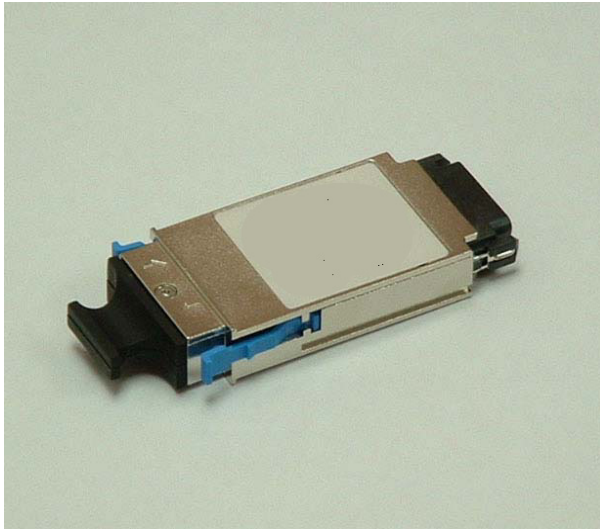

Features

- Compliant with Gigabit Interface Converter Specification
- SCA-2 Host connector
- Duplex SC connector
- Differential PECL inputs and outputs
- Single power supply 3.3V/5V
- TTL signal detect indicator
- Hot Pluggable
- Class 1 laser product complies with EN 60825-1

Application

- Distributed multi-processing
- Switch to switch interface
- High speed I/O for file server
- Bus extension application
- Channel extender, data storage

Ordering Information

PART NUMBER	INPUT/OUTPUT	SIGNAL DETECT	VOLTAGE	TEMPERATURE
GBIC-ZX	AC/AC	TTL	3.3V/5V	0°C to 70°C

Absolute Maximum Ratings

PARAMETER	SYMBOL	MIN	MAX	UNITS	NOTE
Storage Temperature	T_S	-40	85	°C	
Supply Voltage	V_{CC}	-0.5	6.0	V	
Input Voltage	V_{IN}	-0.5	V_{CC}	V	
Output Current	I_o	---	50	mA	
Operating Current	I_{OP}	---	400	mA	

Recommended Operating Conditions

PARAMETER	SYMBOL	MIN	MAX	UNITS	NOTE
Ambient Operating Temperature	T_{AMB}	0	70	°C	
Supply Voltage	V_{CC}	3.1	5.25	V	
Supply Current (3.3V)	$I_{TX} + I_{RX}$	---	300	mA	
Supply Current (5V)	$I_{TX} + I_{RX}$	---	400	mA	

Transmitter Electro-optical Characteristics

$V_{CC} = 3.1\text{ V to }5.25\text{ V}$, $T_A = 0\text{ °C to }70\text{ °C}$

PARAMETER	SYMBOL	MIN	TYP.	MAX	UNITS	NOTE
Output Optical Power 9/125 μm fiber	P_{out}	0	---	+5	dBm	Average
Extinction Ratio	ER	9	---	---	dB	
Center Wavelength	λ_C	1530	1550	1570	nm	
Spectral Width (-20dB)	$\Delta\lambda$	---	---	1	nm	
Side Mode Suppression Ratio	$SNSR$	30	---	---	dB	
Rise/Fall Time, (20–80%)	$T_{r,f}$	---	---	260	ps	
Relative Intensity Noise	RIN	---	---	-120	dB/Hz	
Total Jitter	TJ	---	---	227	ps	
Output Eye	Compliant with IEEE802.3z					
Max. P_{out} TX-DISABLE Asserted	P_{OFF}	---	---	-35	dBm	
Differential Input Voltage	V_{DIFF}	0.65	---	2.0	V	
Transmit Fault Output-Low	TX_FAULT_L	0.0	---	0.5	V	
Transmit Fault Output-High	TX_FAULT_H	2.4	---	V_{CC}	V	
TX_DISABLE Assert Time	t_{off}	---	---	10	μs	
TX_DISABLE Negate Time	t_{on}	---	---	1	ms	
Time to initialize, include reset of TX_FAULT	t_{init}	---	---	300	ms	
TX_FAULT from fault to assertion	t_{fault}	---	---	100	μs	
TX_DISABLE time to start reset	t_{reset}	10	---	---	μs	

Receiver Electro-optical Characteristics

 $V_{CC} = 3.1 \text{ V to } 5.25 \text{ V}, T_A = 0^\circ \text{ C to } 70^\circ \text{ C}$

<i>PARAMETER</i>	<i>SYMBOL</i>	<i>MIN</i>	<i>TYP.</i>	<i>MAX</i>	<i>UNITS</i>	<i>NOTE</i>
Optical Input Power-maximum	P_{IN}	-3	---	---	dBm	BER < 10^{-12}
Optical Input Power-minimum (Sensitivity)	P_{IN}	---	---	-23	dBm	BER < 10^{-12}
Operating Center Wavelength	λ_C	1510	---	1590	nm	
Optical Return Loss	ORL	12	---	---	dB	
Receiver Electrical 3dB Upper Cutoff Frequency	---	---	---	1500	MHz	
Signal Detect-Asserted	P_A	---	---	-23	dBm	
Signal Detect-Deasserted	P_D	-31	---	---	dBm	
Differential Output Voltage	V_{DIFF}	0.37	---	2.0	V	
Data Output Rise, Fall Time (20–80%)	$T_{r,f}$	---	---	0.35	ns	
Receiver Loss of Signal Output Voltage-Low	RX_LOS_L	0	---	0.5	V	
Receiver Loss of Signal Output Voltage-High	RX_LOS_H	2.4	---	V_{CC}	V	
Receiver Loss of Signal Assert Time (off to on)	t_{A,RX_LOS}	---	---	100	μs	
Receiver Loss of Signal Assert Time (on to off)	t_{D,RX_LOS}	---	---	100	μs	

Block Diagram of Transceiver

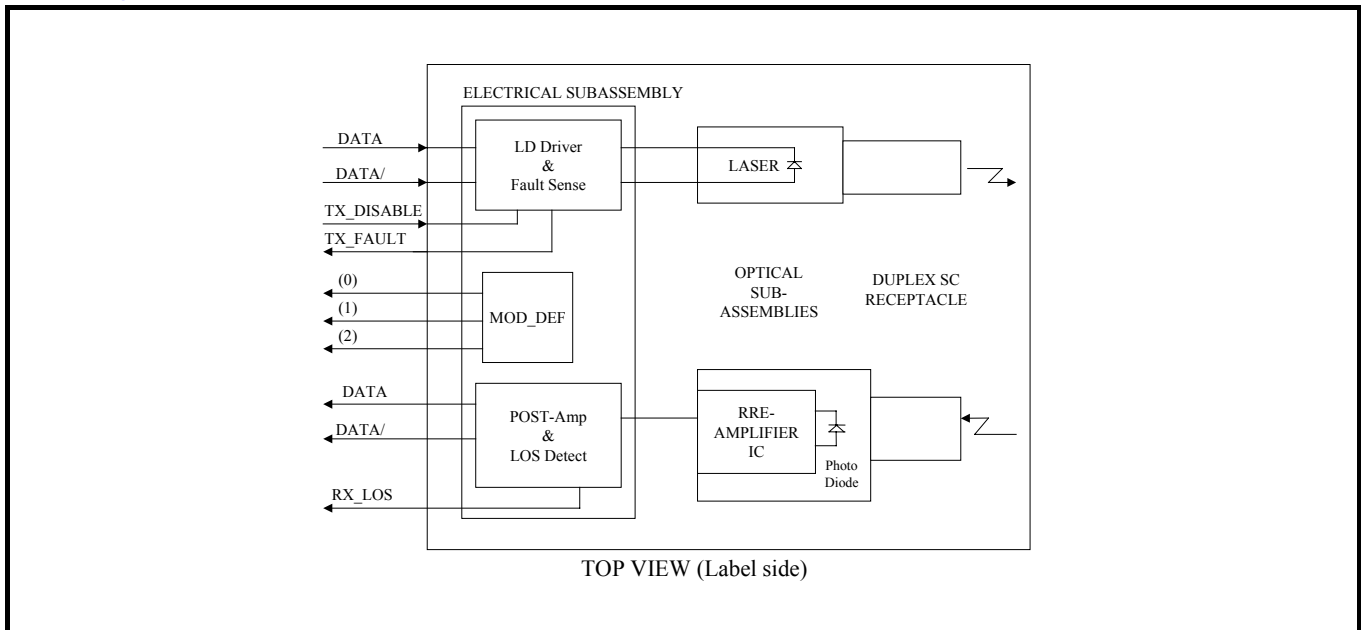

Transmitter Section

The transmitter section consists of a 1550 nm InGaAsP laser in an eye safe optical subassembly (OSA) which mates to the fiber cable. The laser OSA is driven by a LD driver IC which converts differential input PECL logic signals into an analog laser driving current.

TX_FAULT

When sensing an improper power level in the laser driver, the GBIC set this signal high and turns off the Laser. TX_FAULT can be reset with the TX_DISABLE line. The signal is in TTL level.

TX_DISABLE

The TX_DISABLE signal is high (TTL logic "1") to turn off the laser output. The laser will turn on within 1ms when TX_DISABLE is low (TTL logic "0").

Receiver Section

The receiver utilizes an InGaAs PIN photodiode mounted together with a trans-impedance preamplifier IC in an OSA. This OSA is connected to a circuit providing post-amplification quantization, and optical signal detection.

Receive Loss (RX_LOS)

The RX_LOS is high (logic "1") when there is no incoming light from the companion transceiver. This signal is normally used by the system for the diagnostic purpose. The signal is operated in TTL level.

Typical BER Performance of Receiver versus Input Optical Power Level

Dimensions

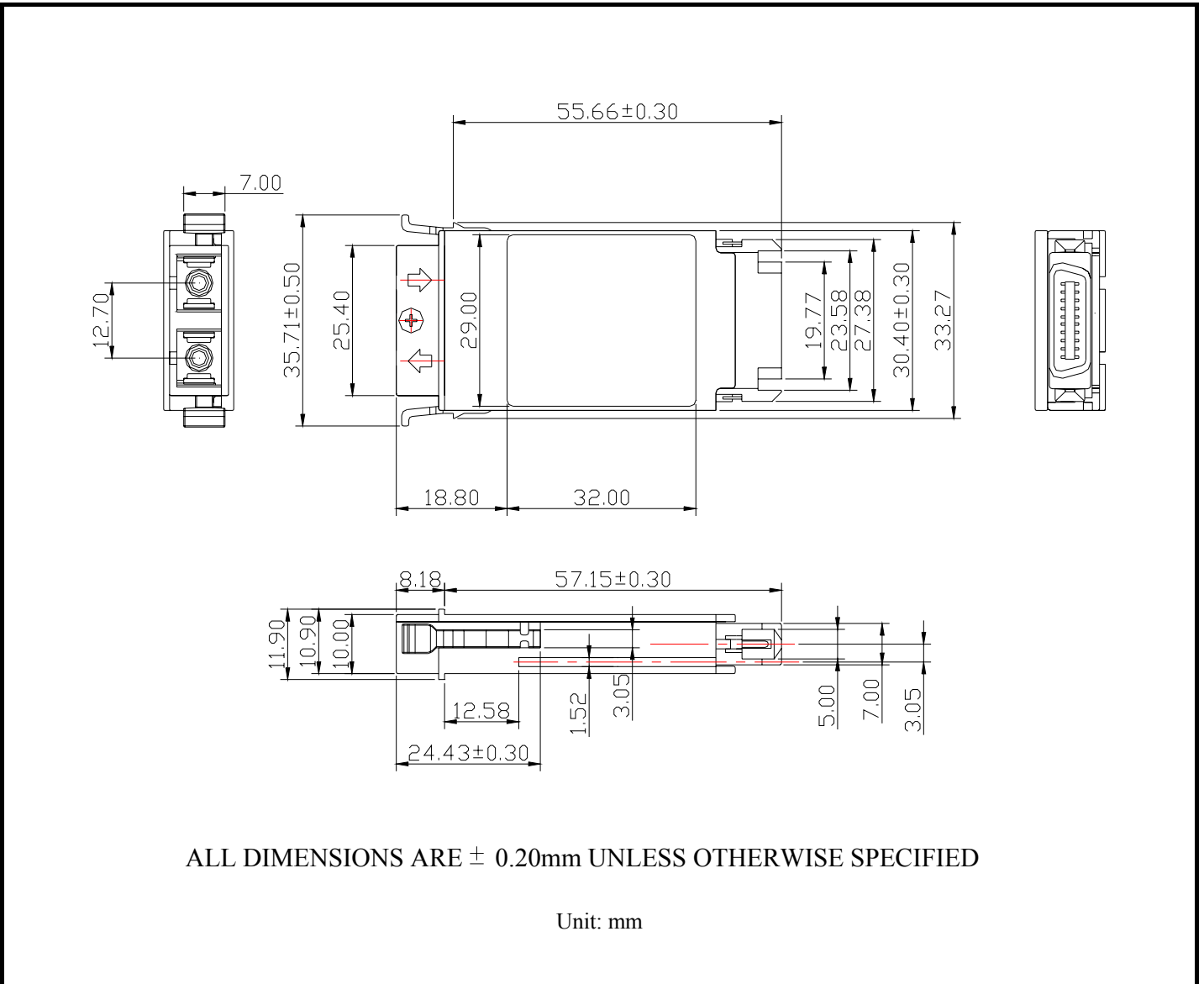

Eye Safety

Multimode transceiver is a class 1 laser product. It complies with EN 60825-1 and FDA 21 CFR 1040.10 and 1040.11. In order to meet laser safety requirements the transceiver shall be operated within the Absolute Maximum Ratings.

Caution

All adjustments have been done at the factory before the shipment of the devices. No maintenance and user serviceable part is required. Tampering with and modifying the performance of the device will result in voided product warranty.

Required Mark

**Class 1 Laser Product
Complies with
21 CFR 1040.10 and 1040.11**